

PARTS MANUAL

Model

EH09

ENGINE

EH090D42000
EH090D42010
EH090D42020
EH090D42030
EH090D42040
EH090D42050
EH090D42060
EH090D42070
EH090D42080
EH090D45010
EH090D45020

PUB-EP5768

Rev. 03/00

1	EH090D42000
2	EH090D42010
3	EH090D42020
4	EH090D42030
5	EH090D42040
6	EH090D42050
7	EH090D42060
8	EH090D42070
9	EH090D42080
10	EH090D45010
11	EH090D45020

Numbers in the remarks columns show corresponding product number. Parts which are not specified with numbers are used in all the products. Please see chart above.

Robin America, Inc.

940 Lively Blvd. • Wood Dale, IL 60191 • Phone: 630-350-8200 • Fax: 630-350-8212
e-mail: sales@robinamerica.com • www.robinamerica.com

© Copyright 2000 Robin America, Inc.

HOW TO USE THIS MANUAL

Robin engines are identified by MODEL, SPECIFICATION, and CODE NUMBER. For each model there may be many different versions called specifications. Each specification will be unique in some way. The difference may only be the paint color or it may have a different type of PTO or some other significant difference.

In order to identify the correct service part number, it is important to confirm the specification and code numbers for your engine. The specification and code number together are known as the PRODUCT NUMBER.

All Robin 4 cycle engines have a Product Number label similar to the label illustrated below.

PRODUCT NUMBER LABEL

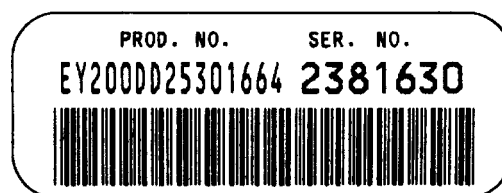

PRODUCT NUMBER LABEL LOCATIONS

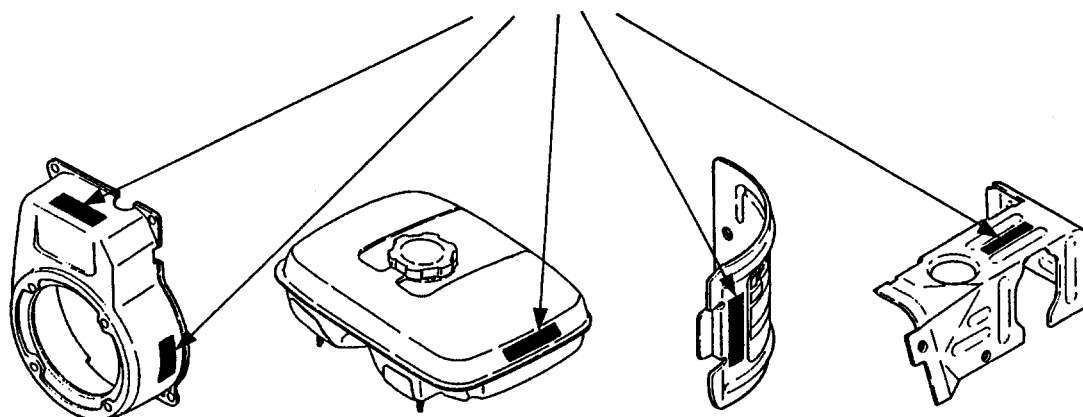

The Product Number Label has a 15 digit alphanumeric string that consists of the SPECIFICATION (SPEC) number (11 digits) and the CODE number (4 digits). Please note the illustration below:

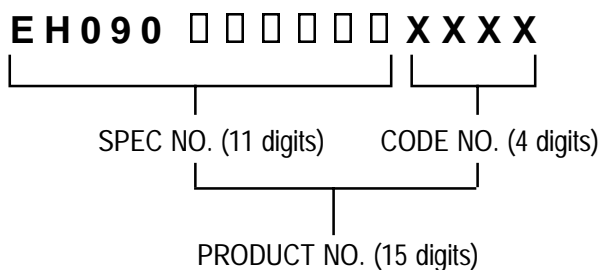

MANUAL LAYOUT

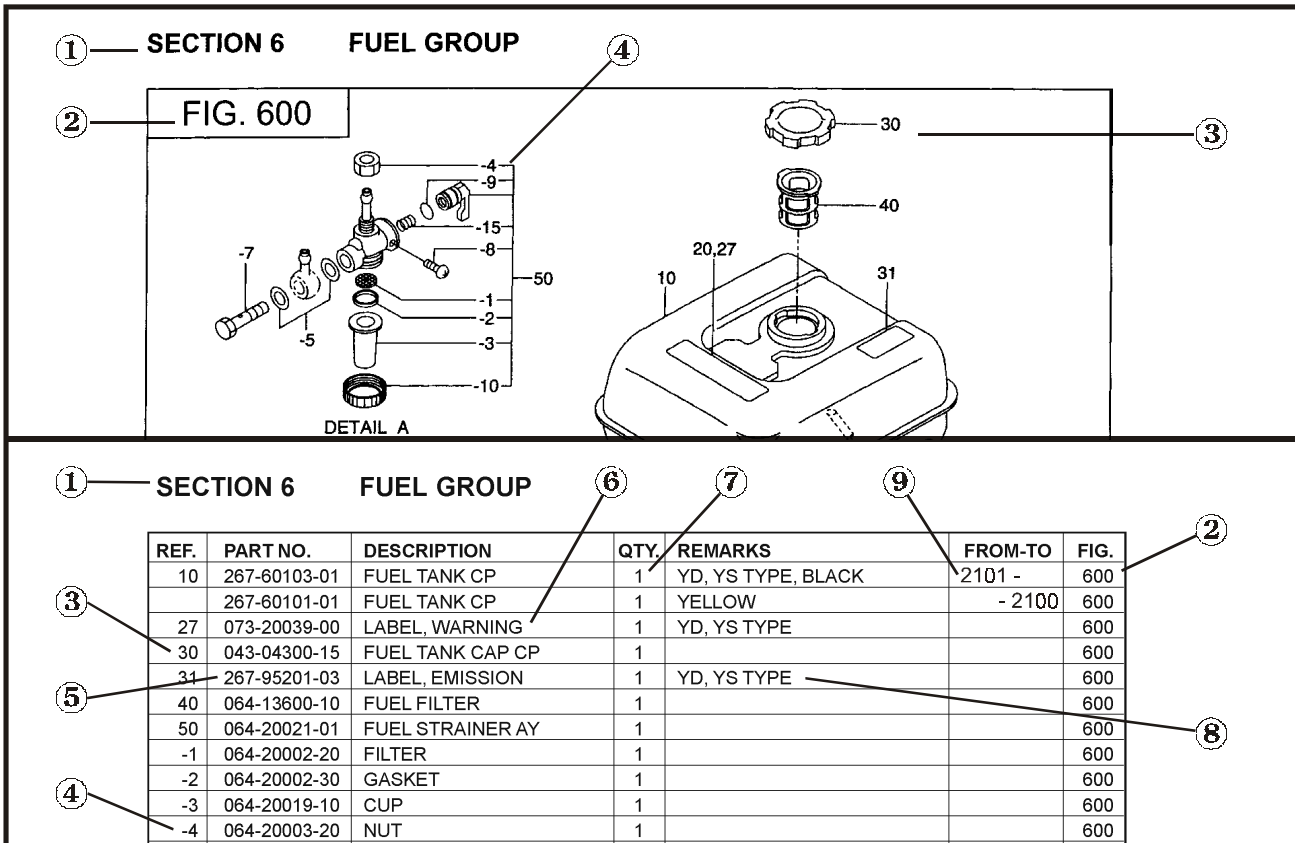

1. SECTION NAME Parts are broadly classified according to their functions. Refer to the Group Index (table of contents) for respective section name.
2. FIG. No. The FIG. number indexes the reference and part numbers to the illustration. Figure numbers that vary only in the tens place (i.e.: 700 and 710) are in a group of the same section (i.e.: Electrical Device Group).
3. REF. No. The Reference number identifies the part illustration with the corresponding part number in the part list.
4. SUBASSEMBLY SUBASSEMBLY parts of part assembly are listed below the assembly part. The subassembly part reference number is indicated by the number led by "-" such as "-1", "-2".
5. PART NUMBER It is the number assigned for sales unit. Use the PART No. when making an order.
6. DESCRIPTION It is designation of the part.
7. QTY. Quantity of each part used for each product.
8. REMARKS This gives a distinctive feature and/or a supplementary comment for the type, the specification, and the part concerned. It also shows part number(s) interchangeable for the part.
9. FROM-TO This section shows the CODE No. to indicate the history of progress in which improved parts have been introduced in the product. The FROM-TO CODE No. helps to identify PART No. being employed in the product concerned. See the examples below:
 - The part is used in the product irrespective of CODE No.
 - 2101- The part is used in the products with CODE No. of 2101 and after this number.
 - 2100 The part is used in the products with CODE No. of 2100 and before this number.

GROUP INDEX

Group Name	Page
CRANKCASE GROUP	6
CRANKSHAFT GROUP	8
INTAKE and EXHAUST GROUP	10
GOVERNOR GROUP	12
COOLING and STARTING GROUP	14
FUEL GROUP - CARBURETOR	16
ELECTRIC DEVICE GROUP	18

INDEX OF DESCRIPTION SYMBOLS			
SYMBOL	DESCRIPTION	SYMBOL	DESCRIPTION
AY	ASSEMBLY	P=	PITCH (in mm)
CP	COMPLETE	P.T.O. (PTO)	POWER TAKE OFF
EX	EXPORT (from Japan)	REF.	REFERENCE
FIG.	FIGURE	R.H. (RH)	RIGHT HAND SIDE
FR.	FRONT	RR.	REAR
"	INCH	STD.	STANDARD
INCL.	INCLUDE	SW	SWITCH
~L	LITER	T=	THICKNESS (in mm)
L=	LENGTH (in. mm)	UN	UNIT
L.H. (LH)	LEFT-HAND SIDE	U.S.	UNDER SIZE
MECH	MECHANICAL	~V	VOLTAGE
NO (NON)	NONE	~W	WATT
OPT.	OPTIONAL	W/	WITH
O.S.	OVER SIZE	W/O	WITHOUT

SECTION 1 CRANKCASE GROUP

FIG. 100

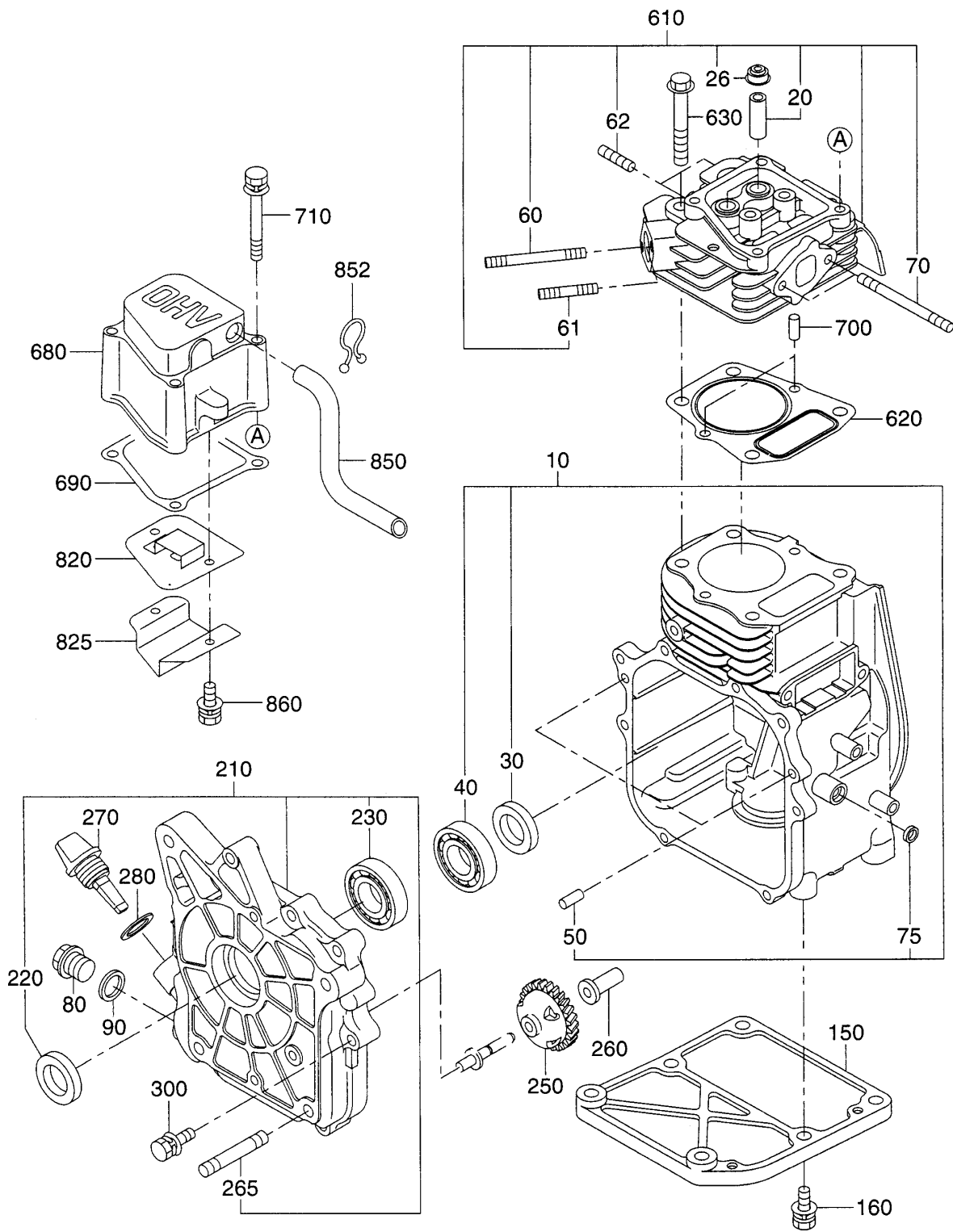

SECTION 1 CRANKCASE GROUP

REF.	PART NO.	DESCRIPTION	QTY.	REMARKS	FROM-TO	FIG.	
10	274-10101-21	CRANKCASE CP	1			100	
20	237-14202-03	VALVE GUIDE	2	Oversize		100	
26	237-16008-01	STEM SEAL	1			100	
30	044-02000-70	OIL SEAL	1	20 X 32 X 6		100	
40	060-02001-40	BALL BEARING	1			100	
50	031-00600-20	DOWEL PIN	2			100	
60	001-39066-00	STUD	1			100	
61	010-50602-00	STUD	1			100	
62	010-50601-70	STUD	2			100	
70	010-50601-60	STUD	2			100	
75	044-00600-10	OIL SEAL	1	6 X 10 X 2.5		100	
80	040-11400-30	PLUG	1			100	
90	021-11400-20	GASKET	1			100	
150	274-16001-13	STIFFENER	1	3, 5, 8-11		100	
160	001-14082-50	BOLT and WASHER AY	2	3, 5, 8-11		100	
210	274-11001-31	MAIN BEARING COVER	1			100	
220	044-02001-10	OIL SEAL	1	20 X 32 X 6		100	
230	060-02001-40	BALL BEARING	1			100	
250	230-45003-01	GOVERNOR GEAR CP	1			100	
260	205-41901-03	GOVERNOR SLEEVE	1			100	
265	001-39085-00	STUD	4			100	
270	230-63601-13	OIL GAUGE	1			100	
280	021-31600-20	GASKET	1			100	
300	013-00602-00	BOLT and WASHER AY	9			100	
610	274-13001-31	CYLINDER HEAD CP	1			100	
620	274-15001-03	GASKET, head	1			100	
630	011-00802-10	FLANGE BOLT	4			100	
680	274-15502-03	ROCKER COVER	1			100	
690	274-1604-03	GASKET, rocker cover	1			100	
700	031-00600-20	DOWEL PIN	2			100	
820	274-14401-01	BREATHER PLATE CP	1			100	
825	274-14405-03	OIL SHELTER PLATE 2	1			100	
850	274-16101-03	BREATHER PIPE	1			100	
852	056-90000-10	PURSE LOCK 1	1			100	
860	001-13051-00	BOLT and WASHER AY	2			100	
*	274-99001-07	GASKET SET	1			100	
		Gasket set includes the following: Fig. 100 items 90, 280, 620, 690 Fig. 300 items 340, 510-2, 550, 560					

SECTION 2 CRANKSHAFT GROUP

FIG. 200

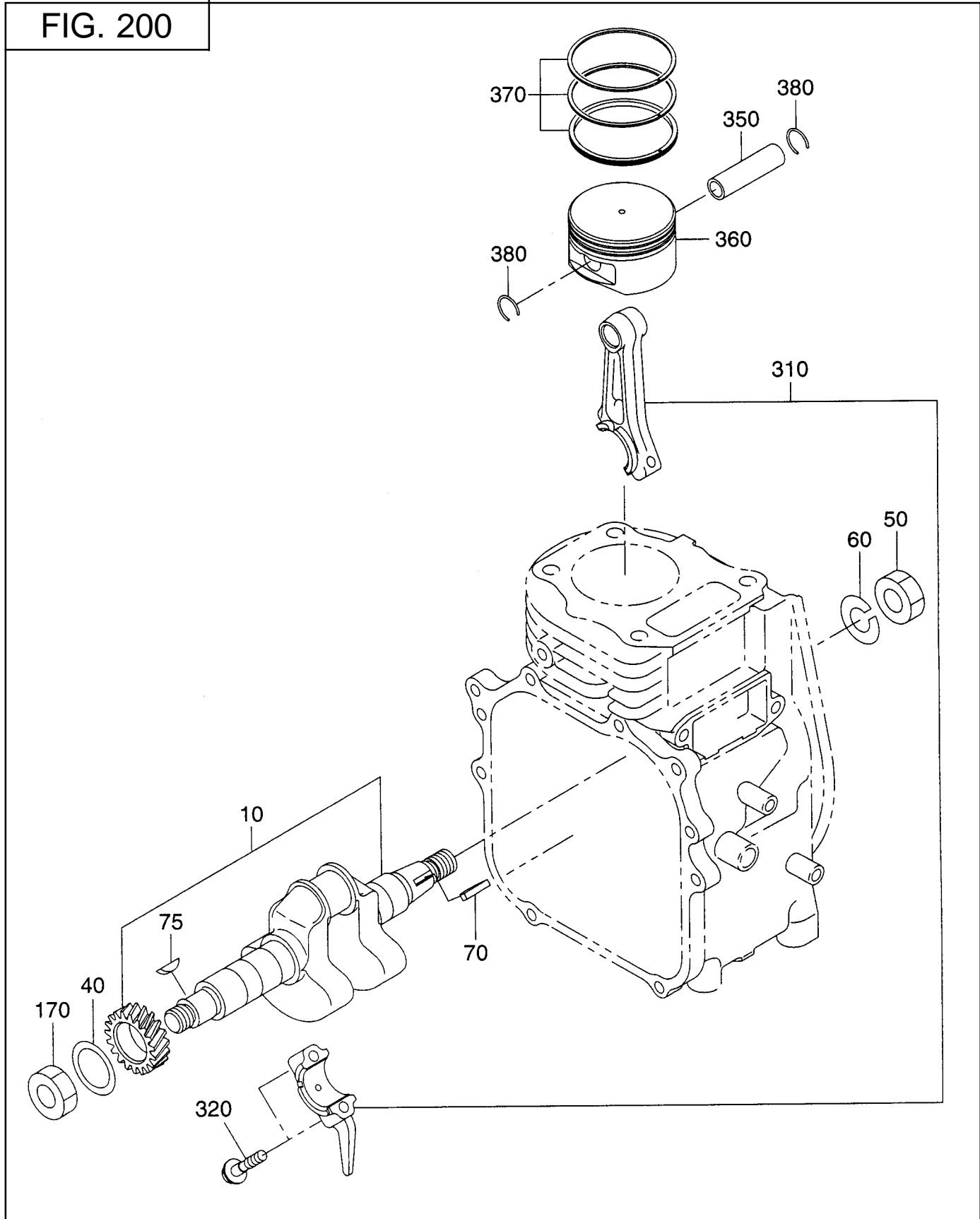

SECTION 3 INTAKE and EXHAUST GROUP

FIG. 300

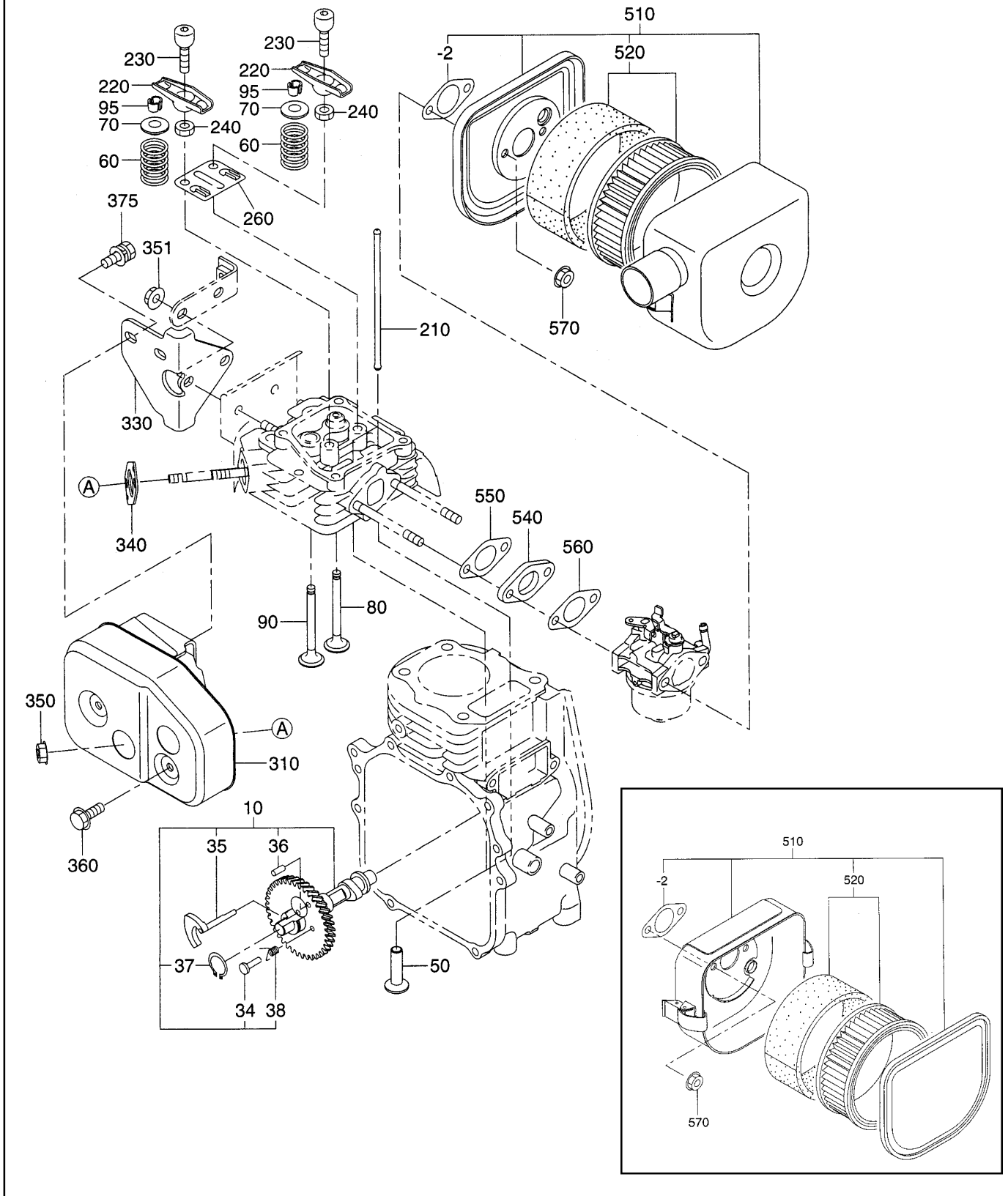

SECTION 3 INTAKE and EXHAUST GROUP

REF.	PART NO.	DESCRIPTION	QTY.	REMARKS	FROM-TO	FIG.
10	274-31701-01	CAMSHAFT CP	1			300
34	227-38601-23	PIN, spring	1			300
35	274-36401-03	RELEASE LEVER	1			300
36	005-19041-00	SPRING PIN	1			300
37	003-15170-00	SNAP RING, outer	1			300
38	274-38701-03	RETURN SPRING	1			300
50	274-33301-03	TAPPET	2			300
60	274-33601-03	VALVE SPRING	2			300
70	274-33701-03	RETAINER , valve spring	2			300
80	274-33401-03	INTAKE VALVE	1			300
90	274-33501-03	EXHAUST VALVE	1			300
95	132-10KA0-31	COLLET VALVE	4			300
210	274-35301-03	PUSH ROD	2			300
220	274-36001-03	ROCKER ARM	2			300
230	269-35801-03	BOLT, pivot	2			300
240	017-00600-90	NUT	2			300
260	274-36501-03	GUIDE PLATE	1			300
310	274-30101-01	MUFFLER CP	1			300
330	274-37001-11	BRACKET , muffler	1			300
340	274-35201-01	GASKET, exhaust	1			300
350	017-60600-20	SELF LOCK NUT	2			300
360	011-00600-10	FLANGE BOLT	2			300
375	001-13061-20	BOLT and WASHER AY	2			300
510	274-32601-00	AIR CLEANER AY	1	1-5, 10, 11		300
	274-32602-00	AIR CLEANER AY	1	6-9, Inset		310
-2	230-32620-08	PACKING	1			300
520	274-32610-07	ELEMENT SET	1	1-5, 10, 11		300
	274-32602-07	ELEMENT SET	1	6-9, Inset		310
540	230-32901-03	INSULATOR	1			300
550	230-35901-03	GASKET, insulator	1			300
560	230-35902-03	GASKET 2, insulator	1			300
570	017-60600-20	SELF LOCKING NUT	2			300

SECTION 4 GOVERNOR GROUP

FIG. 400

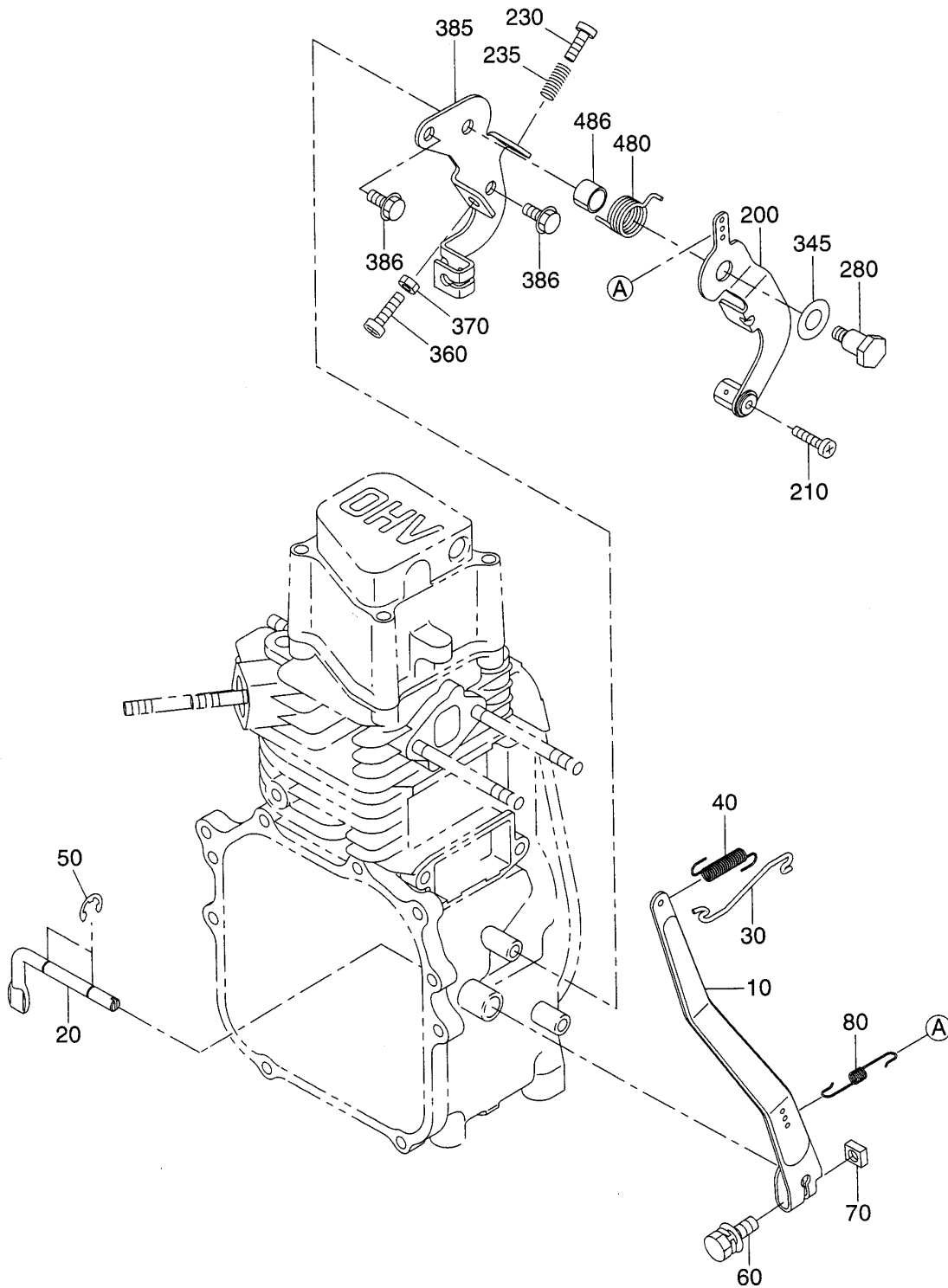

SECTION 5 COOLING and STARTING GROUP

FIG. 500

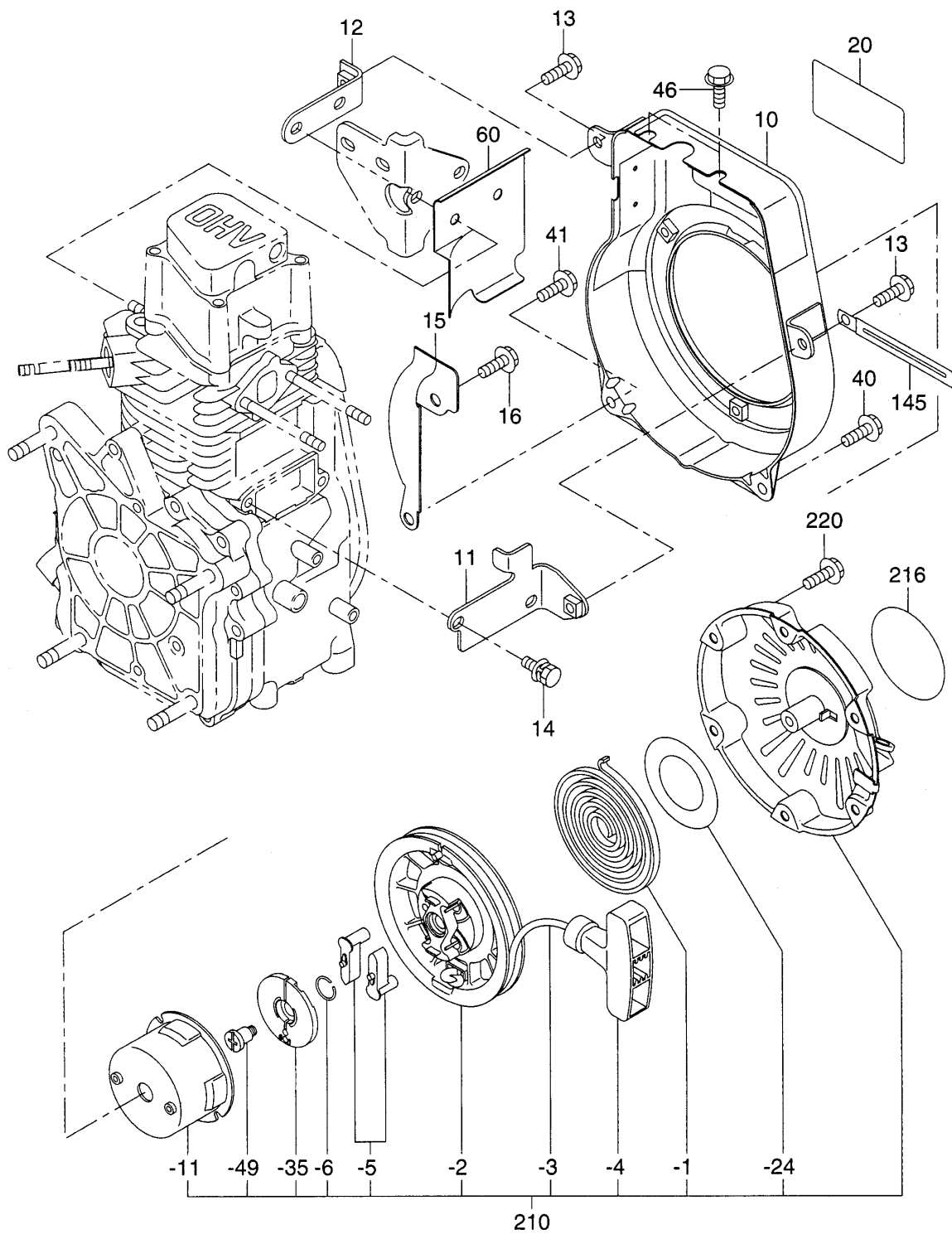

SECTION 5 COOLING and STARTING GROUP

REF.	PART NO.	DESCRIPTION	QTY.	REMARKS	FROM-TO	FIG.
10	274-51202-11	BLOWER HOUSING CP	1	1, 3, 6, 8, 10, 11		500
	274-51204-11	BLOWER HOUSING CP	1	2, 4, 7		500
	274-51209-01	BLOWER HOUSING CP	1	5, 9		500
11	274-55101-21	BRACKET 1,CP	1			500
12	274-55201-01	BRACKET 2, CP	1			500
13	011-060-20	FLANGE BOLT	2			500
14	001-16061-40	BOLT and WASHER AY	2			500
15	274-55001-01	BLOWER GUIDE CP	1			500
16	011-00600-10	FLANGE BOLT	1			500
20	274-91701-03	LABEL, trademark	1	1, 2, 3, 5-10		500
	274-91702-03	LABEL, trademark	1	4, 11		500
40	011-00600-10	FLANGE BOLT	1			500
41	011-00600-20	FLANGE BOLT	1			500
46	011-00600-20	FLANGE BOLT	2			500
60	274-52601-03	CYLINDER BAFFLE	1			500
145	056-60002-50	CLAMP	1	3, 5, 8, 9		500
210	274-50201-20	RECOIL STARTER AY	1			500
-1	274-50115-08	SPIRAL SPRING	1			500
-2	274-50120-18	REEL	1			500
-3	274-50111-08	STARTER ROPE	1			500
-4	261-50100-08	STARTER KNOB	1			500
-5	270-50125-08	RATCHET	2			500
-6	227-50131-08	FRICION SPRING	1			500
-11	274-50145-08	STARTER PULLEY	1			500
-24	131-50150-08	SLIDE PLATE	1			500
-35	270-50261-08	RATCHET GUIDE	1			500
-49	227-50152-08	SET SCREW	1			500
216	206-91701-03	LABEL, trademark	1	10, 11		500
220	011-00600-20	FLANGE BOLT	3			500

SECTION 6 FUEL GROUP - CARBURETOR

FIG. 600

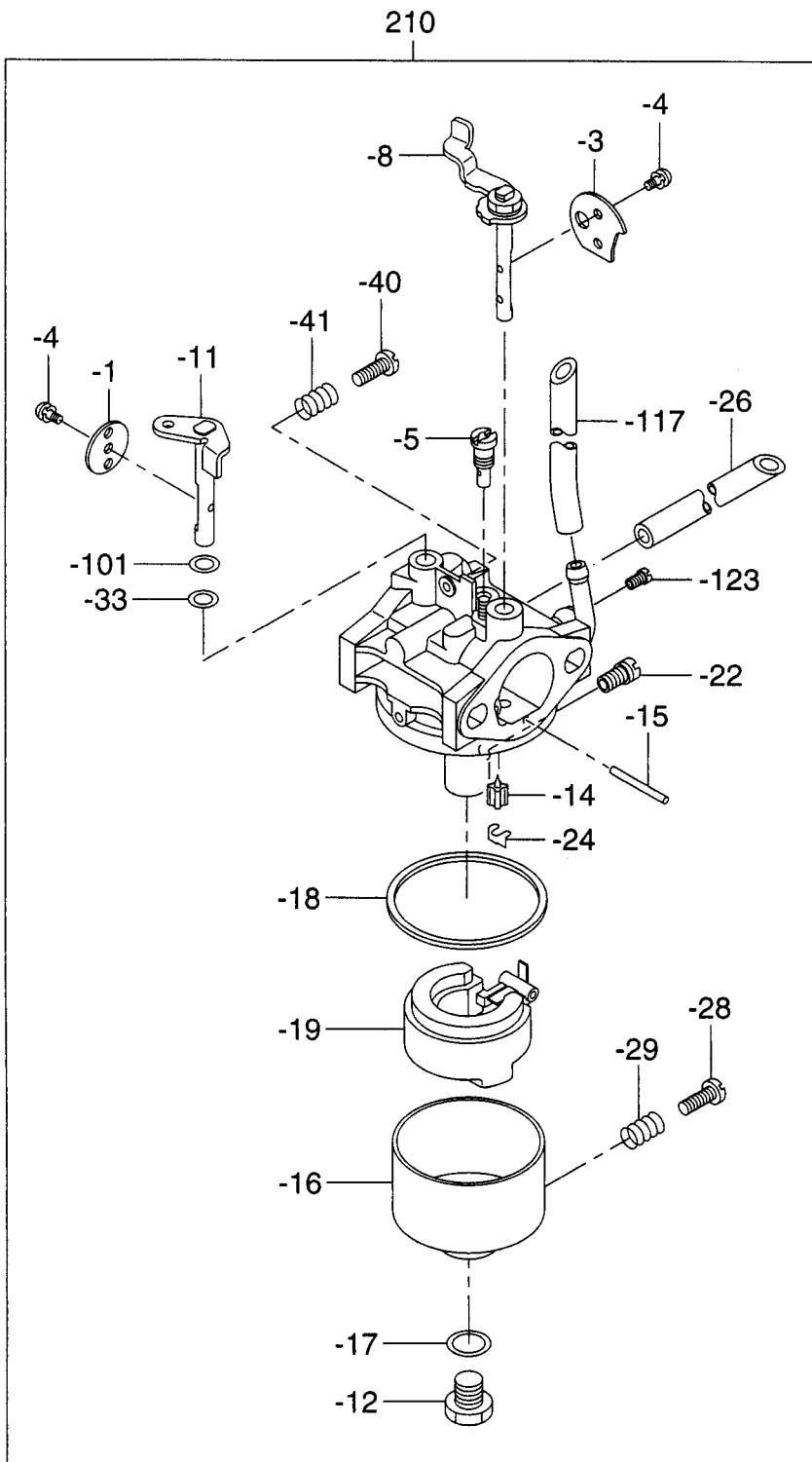

SECTION 7 ELECTRIC DEVICE GROUP

FIG. 700

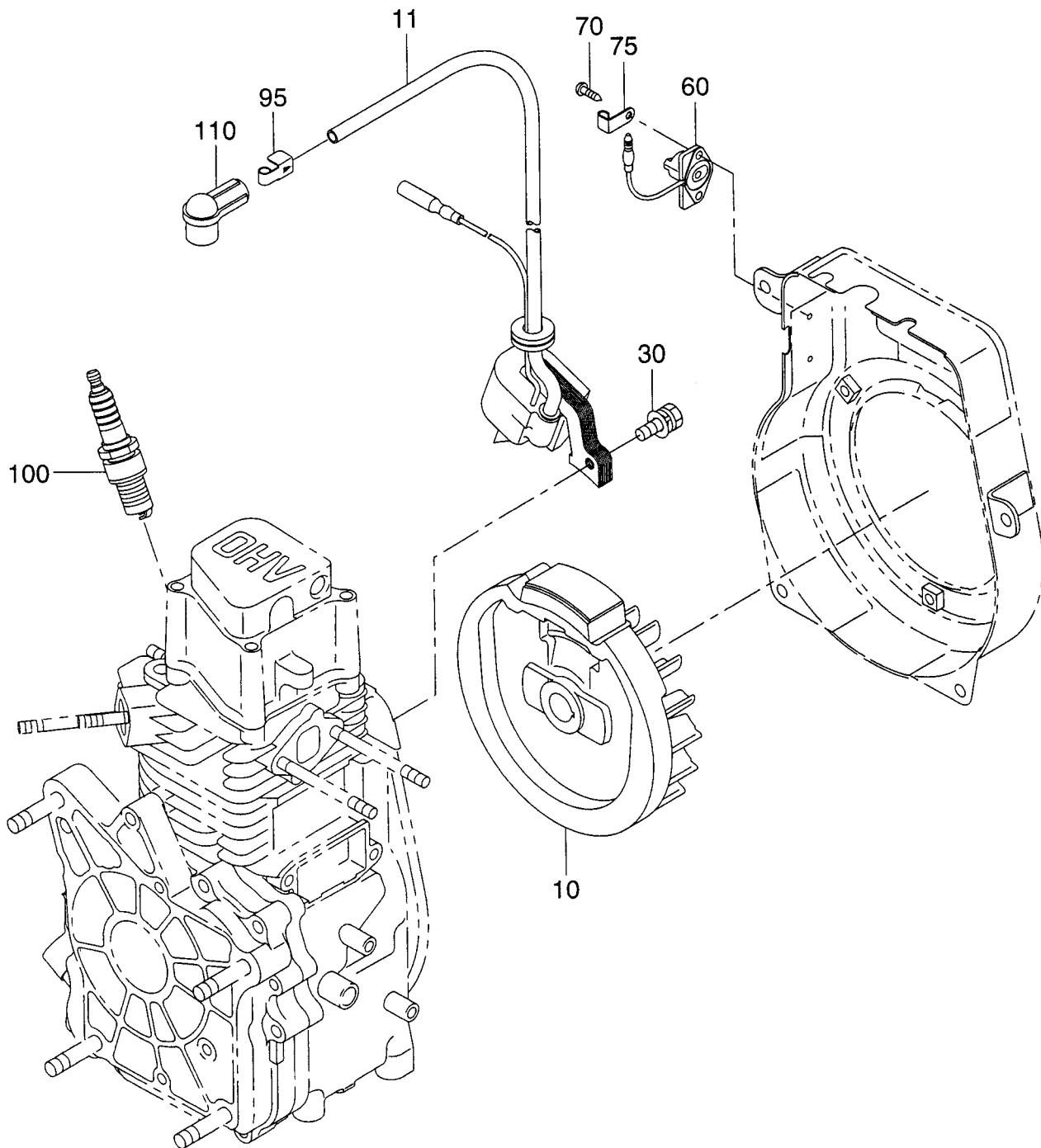
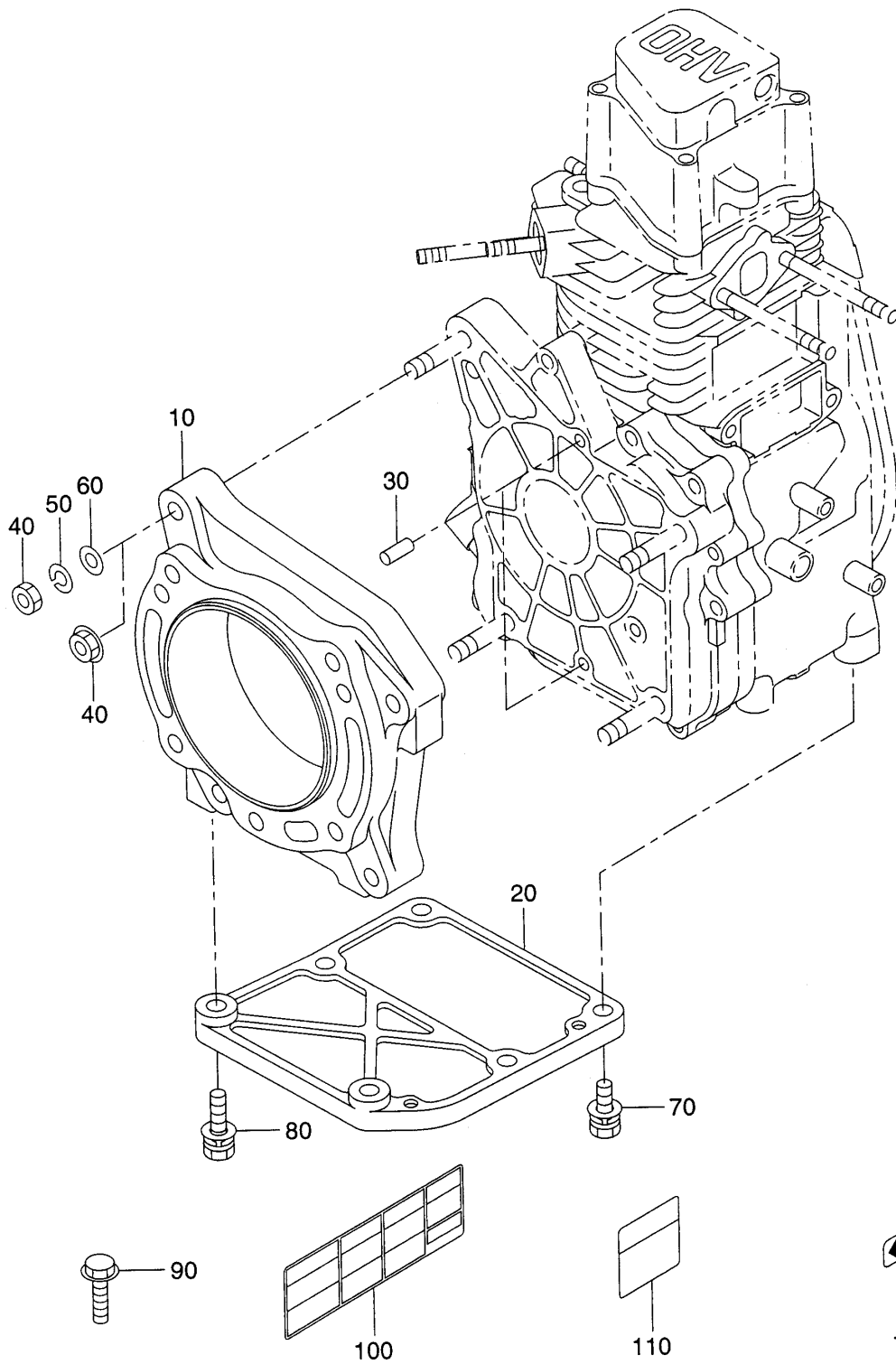

FIG. 800



SECTION 8 LOOSE SHIP PARTS

REF.	PART NO.	DESCRIPTION	QTY.	REMARKS	FROM-TO	FIG.
10	274-15001-23	ADAPTER, flange	1			800
20	274-16001-13	STIFFENER	1	1, 2, 4, 6, 7		800
30	031-0600-20	DOWEL PIN	2			800
40	002-18080-00	NUT	4	1, 2, 4, 6, 7, 10, 11		800
	002-38080-00	FLANGE NUT	4	3, 5, 8, 9		800
50	003-20080-00	SPRING WASHER	4	1, 2, 4, 6, 7, 10, 11		800
60	003-11080-00	WASHER	4	1, 2, 4, 6, 7, 10, 11		800
70	001-14082-50	BOLT and WASHER AY	4	1, 2, 4, 6, 7		800
	001-14082-50	BOLT and WASHER AY	2	3, 5, 8-11		800
80	001-14083-00	BOLT and WASHER AY	2			800
90	001-14084-00	BOLT and WASHER AY	4	10, 11		800
100	073-20047-10	LABEL, caution	1	2, 3, 5-10		800
	073-20044-50	LABEL, caution	1	4, 11		800
110	073-20045-20	LABEL, oil caution	1	3, 5, 6, 8-11		800
120	073-20044-30	LABEL, choke	1	2-11		800

SECTION 8 LOOSE SHIP PARTS

FIG. 810

- ② EH090D42010
- ④ EH090D42030
- ⑦ EH090D42060

- ⑥ EH090D42050

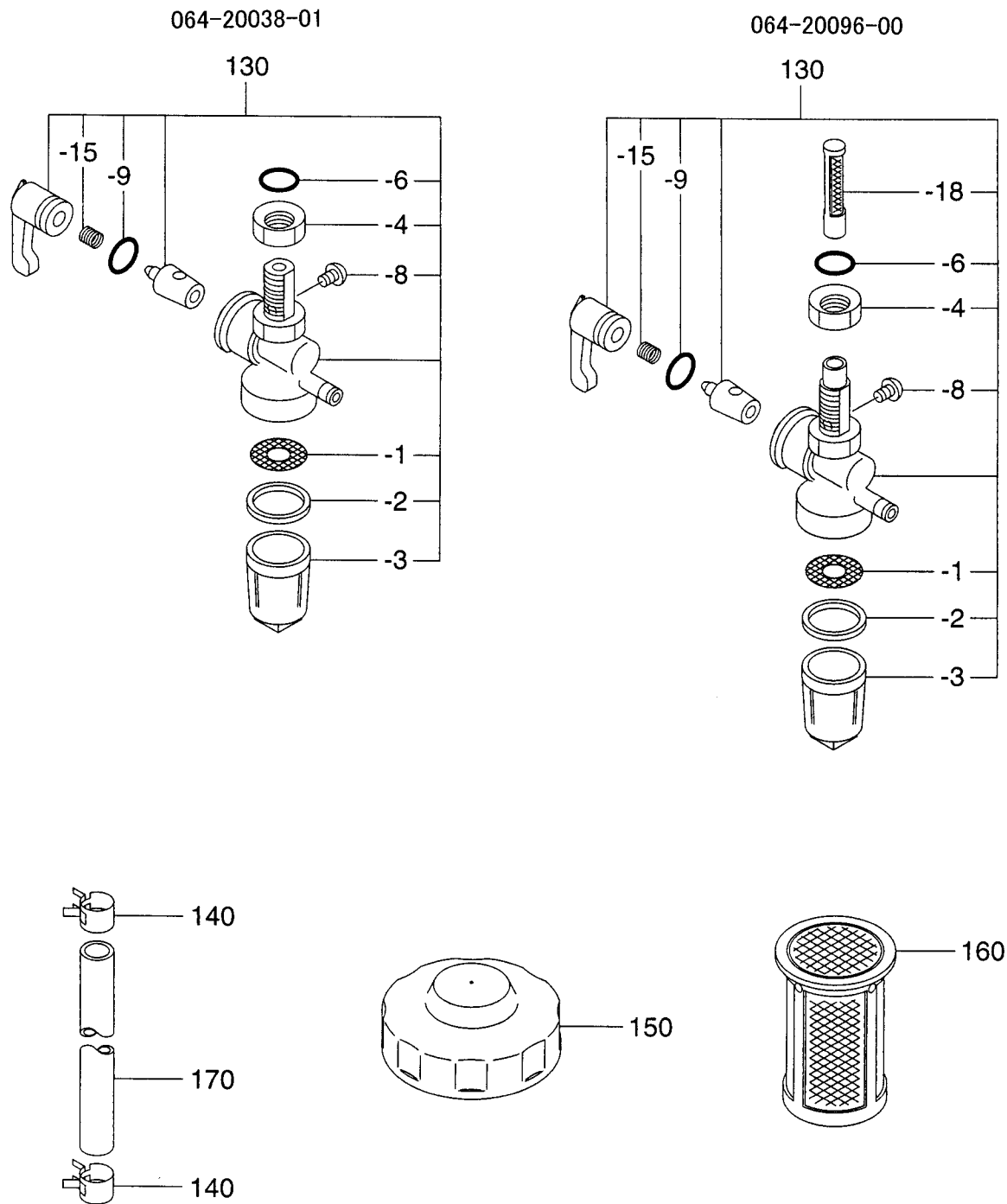

PRINTED IN THE USA